

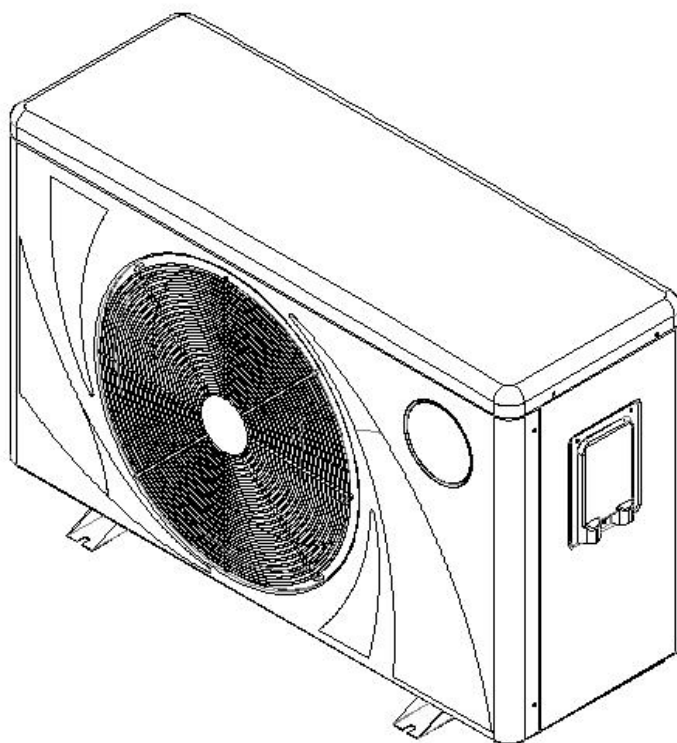

SPA  **LAGERET.DK**

DC Inverter Swimming Pool Heat Pump User and Service manual



INDEX

1. Specifications
2. Dimension
3. Installation and connection
4. Accessories
5. Electrical Wiring
6. Display Controller Operation
7. Running data setting
8. Troubleshooting
9. Maintenance
10. WIFI Controller Function Specification

Thank you for using swimming pool heat pump for your pool heating, it will heat your pool water and keep a constant temperature when the ambient air temperature is at -7 to 43°C

▲ ATTENTION: This manual includes all the necessary information about the use and the installation of your heat pump.

The installer must read the manual and attentively follow the instructions of implementation and maintenance.

The installer is responsible for the installation of the product and should follow all the instructions of the manufacturer and the regulations in application. Incorrect installation against the manual implies the exclusion of the entire guarantee.

The manufacturer declines any responsibility for the damage caused to people, object and for errors due to the installation against the manual. Any use that isn't in accordance with the origin of its manufacturing will be regarded as dangerous.



WARNING:

Do not use means to accelerate the defrosting process or to clean, Other than those recommended by the manufacturer.

The appliance shall be stored in a room without continuously operating ignition sources (for example: open flames, an operating gas appliance or an operating electric heater.)

Do not pierce or burn.

Be aware that refrigerants may not contain an odour.

Appliance shall be installed, operated and stored in a room with a floor area larger than X m².

NOTE The manufacturer may provide other suitable examples or may provide additional information about the refrigerant odour.

WARNING: Please empty the water in heat pump always during winter time or when the ambient temperature drops below 0°C, or else the Titanium exchanger will be damaged because of being frozen, in such case, your warranty will be lost.

WARNING: Please always cut the power supply if you want to open the cabinet to reach inside the heat pump, because there is high voltage electricity inside.

WARNING: Please keep the display controller in a dry area, or close the insulation cover to protect the display controller from being damaged by humidity.

1. Specifications

1.1 Technical data

Product model		PW010-KZXYC-H	PW015-KZXYC-H	PW020-KZXYC-H	PW030-KZXYC-H	
Advised pool volume(m3)(with cover)		15~30	20~40	25~50	30~60	
Operating ambient temperature range (°C)		-7 ~43				
Parameters	heating*	Heating capacity (kW)	7.50~1.92	9.50~2.10	11.00~2.50	14.00~3.15
		Heating capacity (BTU/h)	25500~6528	32300~7140	37400~8500	47600~10710
		Input power (kW)	1.15~0.13	1.46~0.14	1.83~0.17	2.15~0.21
		COP	6.5~14.8	6.5~15.0	6.0~14.7	6.5~15.0
		COP at 50% capacity	10.50	11.00	11.00	10.50
	heating**	Heating capacity (kW)	5.80~1.42	7.2~1.50	8.5~1.65	10.7~2.40
		Heating capacity (BTU/h)	19720~4828	24480~5100	28900~5610	36380~8160
		Input power (kW)	1.15~0.20	1.43~0.21	1.77~0.23	2.12~0.34
		COP	5.0~7.1	5.0~7.2	4.8~7.2	5.0~7.1
		COP at 50% capacity	6.50	6.50	6.50	6.50
	Rated current(A)		5.1~0.9	6.3~0.9	7.8~1.0	9.3~1.5
	Minimum fuse current (A)		10	12	15	20
	Advised water flux (m ³ /H)		2~4	2~4	3~5	4~6
	IP Grade (Level of protection)		IPX4	IPX4	IPX4	IPX4
	Anti-electric shock Rate		I	I	I	I
	Nosie	Noise (dB(A)) (1m)	38~48	38~48	40~50	42~51
		Sound pressure of 50% capacity at 1m dB(A)	40	40	41	43
Sound pressure at 10m dB(A)		18~25	18~25	19~26	22~27	
Net weight/Gross weight(kg)		62/70	62/70	64/72	77/87	
Diameter of pipe (mm)		φ50				
Standard Configuration	Metel plate		ABS plastic casing black color			
	Body size(W*D*H)mm		1000X396X640			
	Compressor		Panasonic			
	Refrigerant consumption (g)		R32/350g	R32/380g	R32/450g	R32/550g
	Power supply		220V/1p/ 50Hz/60HZ			
	Condenser		Titanium in PVC			
	Controller		Single System (CHICO)			
	Power line connect with unit		3*1.5mm2	3*1.5mm2	3*2.5mm2	3*2.5mm2
Remark:heating*: working condition, Inlet water temperature 26°C, Outlet water temperature 28°C, Dry bulb temperature 27°C.Humidity 80%.						
heating**: working condition, Inlet water temperature 26°C, Outlet water temperature 28°C, Dry bulb temperature 15°C.Humidity 70%.						

Product model		PW040-KZXYC-H	PW050-KZXYC-H	PW060-KZXYC-H	
Advised pool volume (m ³) (with cover)		40~75	55~100	60~110	
Operating ambient temperature range (°C)		-7 ~43			
Parameters	heating*	Heating capacity (kW)	17.00~3.75	20.00~4.00	24.00~4.80
		Heating capacity (BTU/h)	57800~13090	68000~13600	81600~16320
		Input power (kW)	2.62~0.25	3.33~0.27	4.00~0.32
		COP	6.5~15.0	6.0~14.8	6.0~15.0
		COP at 50% capacity	11.00	11.00	11.00
	heating**	Heating capacity (kW)	13.0~2.65	15.6~2.85	18.7~3.42
		Heating capacity (BTU/h)	44200~9010	53040~9690	63580~11630
		Input power (kW)	5.0~7.4	3.25~0.40	3.89~0.49
		COP	4.56~7.19	4.8~7.0	4.8~7.0
		COP at 50% capacity	6.50	6.50	6.50
	Rated current(A)		11.3~1.6	14.3~1.8	17.8~2.3
	Minimum fuse current (A)		22	30	35
	Advised water flux (m ³ /H)		6~9	8~10	9~12
	IP Grade (Level of protection)		IPX4	IPX4	IPX4
	Anti-electric shock Rate		I	I	I
	Noise	Noise (dB(A)) (1m)	43~52	43~53	44~54
		Sound pressure of 50% capacity at 1m dB(A)	44	44	45
Sound pressure at 10m dB(A)		23~30	24~31	25~32	
Net weight/Gross weight(kg)		81/91	81/91	90/100	
Diameter of pipe (mm)		φ50			
Standard Configuration	Metal plate		ABS plastic casing black color		
	Body size(W*D*H)mm		1125X416X765		
	Compressor		Panasonic		
	Refrigerant consumption (g)		R32/750g	R32/800g	R32/1200g
	Power supply		220V/1p/ 50Hz/60HZ		
	Condenser		Titanium in PVC		
	Controller		Single System (CHICO)		
	Power line connect with unit		3*4.0mm ²	3*6.0mm ²	3*6.0mm ²
<p>Remark:heating*: working condition, Inlet water temperature 26°C, Outlet water temperature 28°C, Dry bulb temperature 26°C.Humidity 80%.</p> <p>heating**: working condition, Inlet water temperature 26°C, Outlet water temperature 28°C, Dry bulb temperature 15°C.Humidity 70%.</p>					

* Above data are subjects to modification without notice.

2. Dimension

2.1 Unit mm

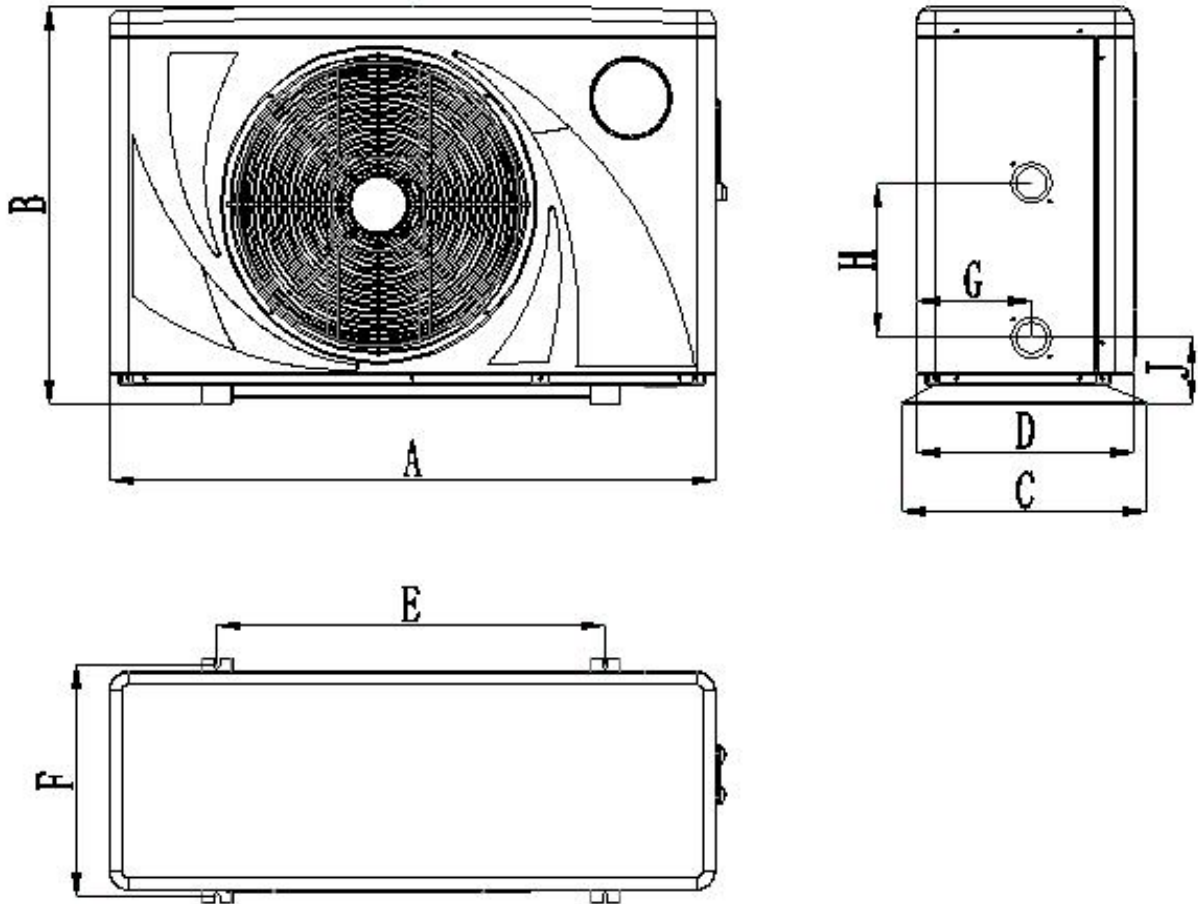

Units: mm		A	B	C	D	E	F	G	H	J
Model										
PW010/015/020/030-KZXYC-H		982	640	396	352	630	371	187	250	106
PW040/050-KZXYC-H		1106	764	416	378	745	391	198	300	
PW060-KZXYC-H									340	

2.2 Exploded viewse

PW010/015/020/030/040/050/060-KZXYC-H

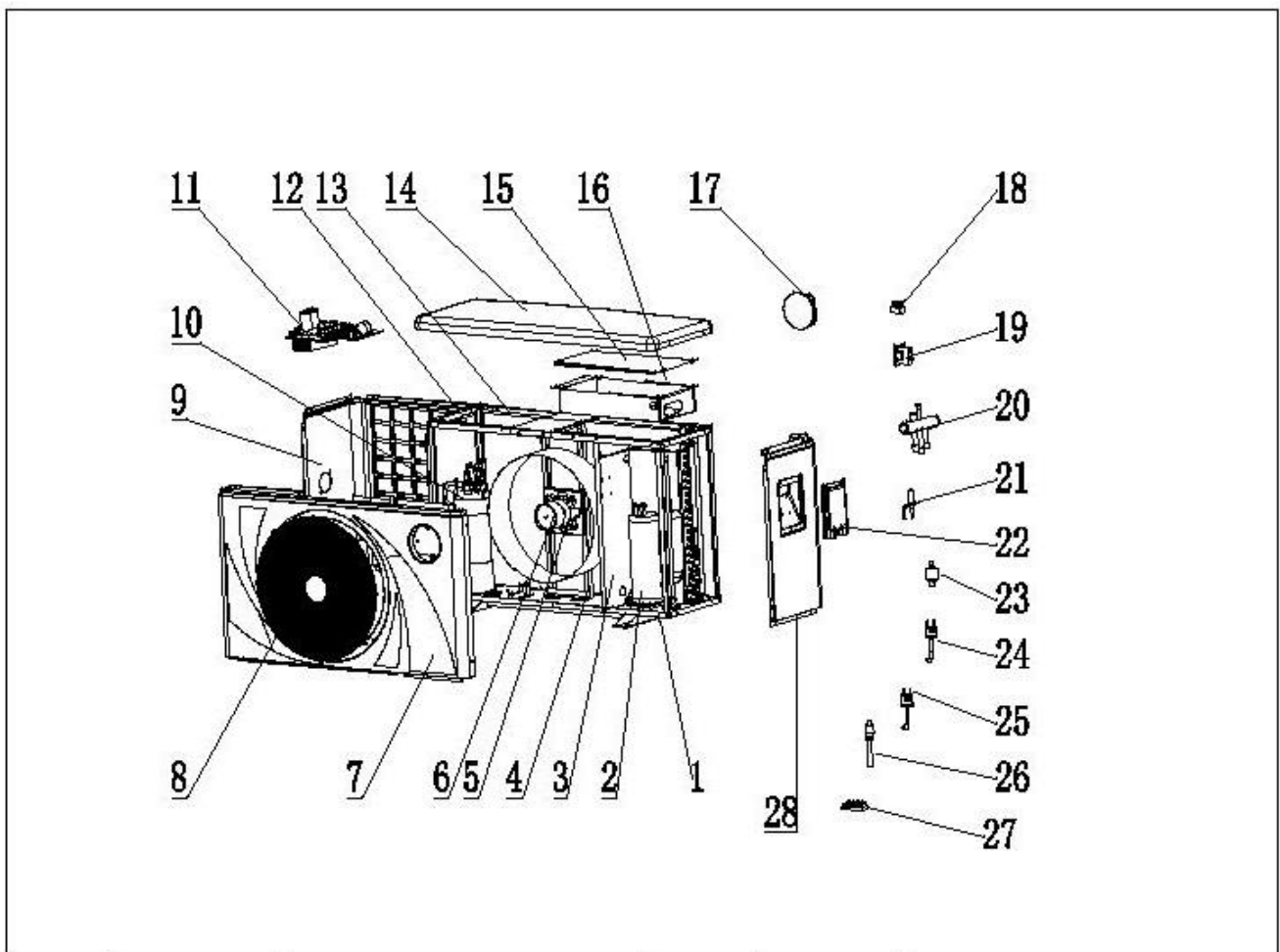

NO	Spare parts	NO	Spare parts
1	chassis	15	electric box cover
2	compressor	16	electric box
3	intermediate partition	17	wire controller
4	motor bracket	18	transfer terminal block
5	motor	19	reactance
6	fan blade	20	4-way valve
7	front panel	21	electronic expansion valve
8	fan guard net	22	junction box cover
9	back net	23	filter
10	Titanium tube heat exchanger	24	high voltage switch
11	control board	25	low voltage switch
12	top frame	26	needle valve
13	fin heat exchanger	27	terminal block
14	top panel	28	right side panel

3. Installation and connection

3.1 Notes

The factory only supplies the heat pump. All other components, including a bypass if necessary, must be provided by the user or the installer.

Attention:

Please observe the following rules when installing the heat pump:

1. Any addition of chemicals must take place in the piping located **downstream** from the heat pump.
2. Install a bypass if the water flow from the swimming pool pump is more than 20% greater than the allowable flow through the heat exchanger of the heat pump.
3. Install the heat pump above the water level of the swimming pool.
4. Always place the heat pump on a solid foundation and use the included rubber mounts to avoid vibration and noise.
5. Always hold the heat pump upright. If the unit has been held at an angle, wait at least 24 hours before starting the heat pump.

3.2 Heat pump location

The unit will work properly in any desired location as long as the following three items are present:

- 1. Fresh air – 2. Electricity – 3. Swimming pool filters**

The unit may be installed in virtually any **outdoor** location as long as the specified minimum distances to other objects are maintained (see drawing below). Please consult your installer for installation with an indoor pool. Installation in a windy location does not present any problem at all, unlike the situation with a gas heater (including pilot flame problems).

ATTENTION: Never install the unit in a closed room with a limited air volume in which the air expelled from the unit will be reused, or close to shrubbery that could block the air inlet. Such locations impair the continuous supply of fresh air, resulting in reduced efficiency and possibly preventing sufficient heat output.

See the drawing below for minimum dimensions.

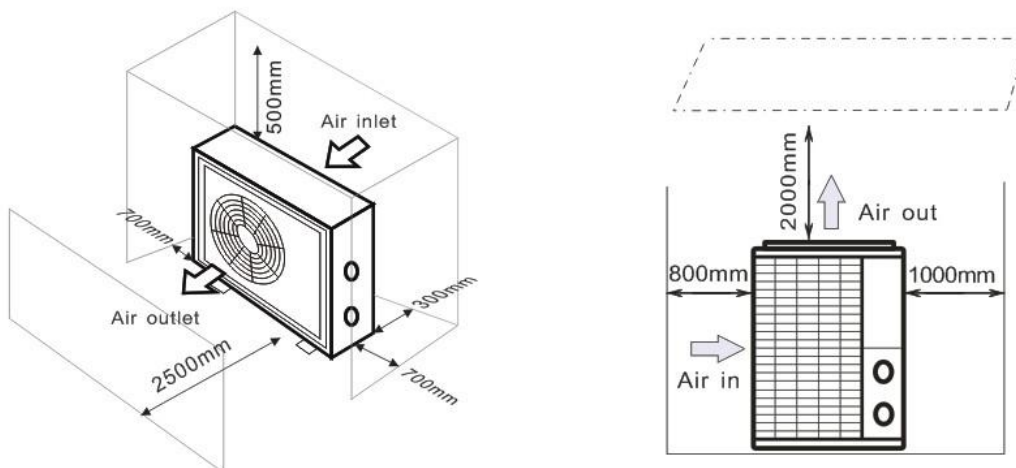

3.3 Distance from your swimming pool

The heat pump is normally installed within a perimeter area extending 7.5 m from the swimming pool. The greater the distance from the pool, the greater the heat loss in the pipes. As the pipes are mostly underground, the heat loss is low for distances up to 30 m (15 m from and to the pump; 30 m in total) unless the ground is wet or the groundwater level is high. A rough estimate of the heat loss per 30 m is 0.6 kWh (2,000 BTU) for every 5 °C difference between the water temperature in the pool and the temperature of the soil surrounding the pipe. This increases the operating time by 3% to 5%.

3.4 Check-valve installation

Note: If automatic dosing equipment for chlorine and acidity (pH) is used, it is essential to protect the heat pump against excessively high chemical concentrations which may corrode the heat exchanger. For this reason, equipment of this sort must always be fitted in the piping on the **downstream** side of the heat pump, and it is recommended to install a check-valve to prevent reverse flow in the absence of water circulation.

Damage to the heat pump caused by failure to observe this instruction is not covered by the warranty.

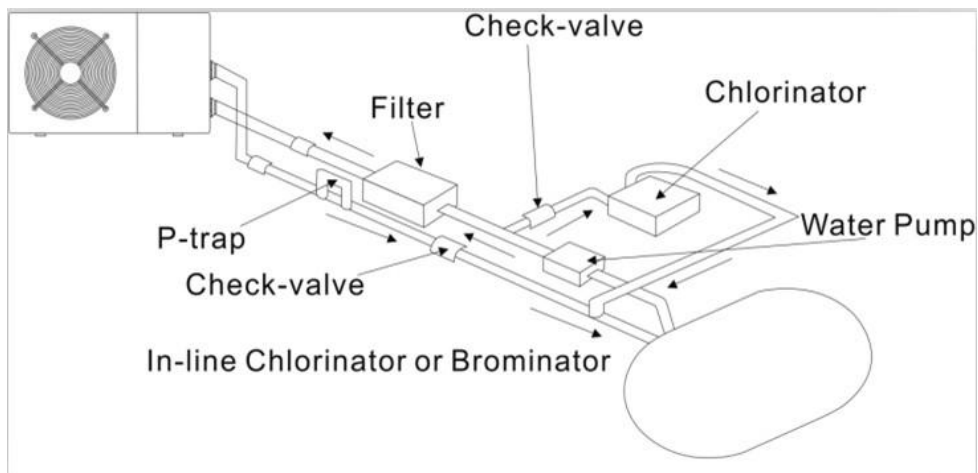

3.5 Typical arrangement

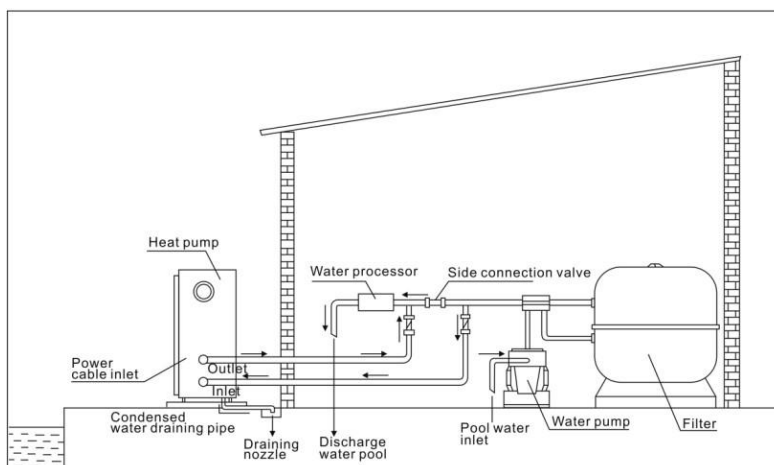

Note: This arrangement is only an illustrative example.

3.6 Adjusting the bypass

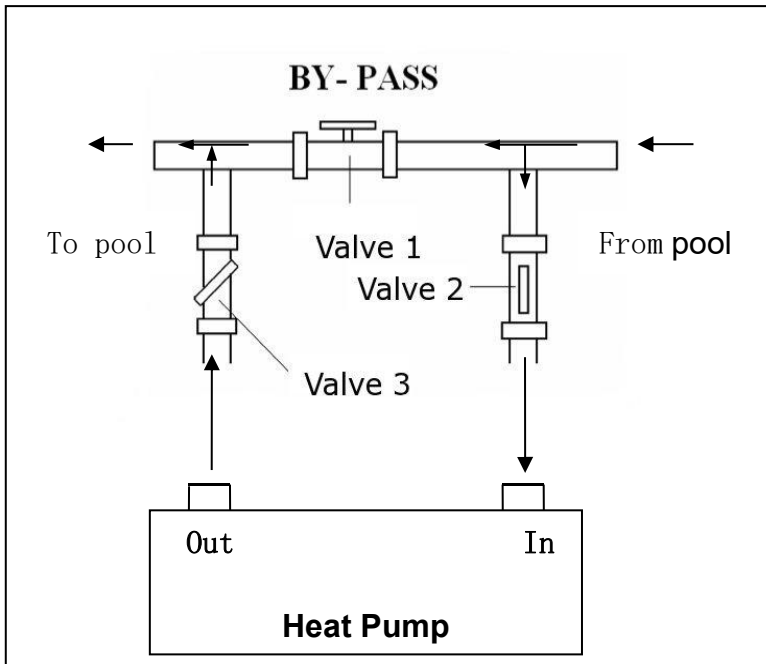

Use the following procedure to adjust the bypass:

- fully open all three valves
- slowly close valve 1 until the water pressure is increased by approximately 100 to 200 g
- Close valve 3 approximately half-way to adjust the gas pressure in the cooling system
- If the display shows error code E03, close valve 1 step by step, to increase water flow and stop when the code disappears.

Optimal operation of the heat pump occurs when the cooling gas pressure is 22 ± 2 bar. This pressure can be read on the pressure gauge next to the control heat pump panel. Under these conditions the water flow through the unit is also optimal.

Note: Operation without a bypass or with improper bypass adjustment may result in sub-optimal heat pump operation and possibly damage to the heat pump, which renders the warranty null and void.

3.7 Electrical connection

Note: Although the heat pump is electrically isolated from the rest of the swimming pool system, this only prevents the flow of electrical current to or from the water in the pool. Earthing is still required for protection against short-circuits inside the unit.

Always provide a good earth connection.

Before connecting the unit, verify that the supply voltage matches the operating voltage of the heat pump.

It is recommended to connect the heat pump to a circuit with its own fuse or circuit breaker (slow type; curve D) and to use adequate wiring (see table below).

Connect the electrical wires to the terminal block marked 'POWER SUPPLY'.

A second terminal block marked 'WATER PUMP' is located next to the first one. The filter pump (max. 5 A / 240 V) can be connected to the second terminal block here. This allows the filter pump operation to be controlled by the heat pump.

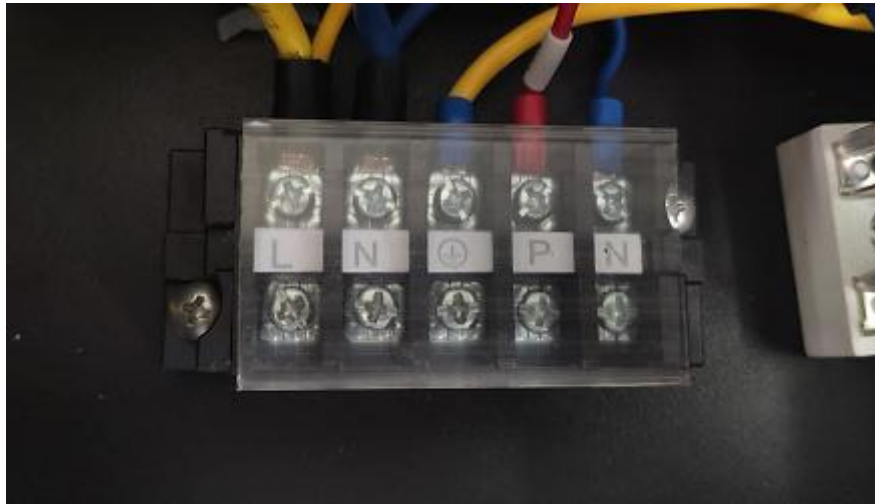

Note: In the case of three-phase models, swapping two phases may cause the electric motors to run in the reverse direction, which can lead to damage. For this reason, the unit has a built-in protective device that breaks the circuit if the connection is not correct. If the red LED above this safety device lights up, **you must swap the connections of two of the phase wires.**

Model	Voltage (V)	Fuse or circuit breaker (A)	Rated current (A)	Wire diameter mm ² (with max. 15 m length)
PW010-KZXYS-H	220–240	10	4.4	3*1.5mm ²
PW015-KZXYS-H	220–240	12	6.9	3*1.5mm ²
PW020-KZXYS-H	220–240	15	8.5	3*2.5mm ²
PW030-KZXYS-H	220–240	20	11.7	3*2.5mm ²
PW040-KZXYS-H	220–240	22	16.2	3*4mm ²
PW050-KZXYS-H	220–240	30	18.7	3*6mm ²
PW060-KZXYS-H	220–240	30	18.7	3*6mm ²

3.8 Initial operation

Note: In order to heat the water in the pool (or hot tub), the filter pump must be running to cause the water to circulate through the heat pump. The heat pump will not start up if the water is not circulating.

After all connections have been made and checked, carry out the following procedure:

1. Switch on the filter pump. Check for leaks and verify that water is flowing from and to the swimming pool.
2. Connect power to the heat pump and press the On/Off button  on the electronic control panel. The unit will start up after the time delay expires (see below).
3. After a few minutes, check whether the air blowing out of the unit is cooler.
4. When you turn off the filter pump, the unit should also turn off automatically, if not adjust the flow switch.

5. Allow the heat pump and the filter pump to run 24 hours a day until the desired water temperature is reached. The heat pump will stop running at this point. After this, it will restart automatically (as long as the filter pump is running) whenever the swimming pool water temperature drops 2 degrees below the set temperature.

Depending on the initial temperature of the water in the swimming pool and the air temperature, it may take several days to heat the water to the desired temperature. A good swimming pool cover can dramatically reduce the required length of time.

Water Flow Switch:

It is equipped with a flow switch to prevent the heat pump of running with inadequate water flow rate. It will turn on when the pool pump runs and shuts off when the pump shuts off. If the pool water level is more than 1m above or below the heat pump’s automatic adjustment knob, your dealer may need to adjust its initial startup.

Time delay -The heat pump has a built-in 3-minute start-up delay to protect the circuitry and avoid excessive contact wear. The unit will restart automatically after this time delay expires. Even a brief power interruption will trigger this time delay and prevent the unit from restarting immediately. Additional power interruptions during this delay period do not affect the 3-minute duration of the delay.

3.9 Condensation

The air drawn into the heat pump is strongly cooled by the operation of the heat pump for heating the pool water, which may cause condensation on the fins of the evaporator. The amount of condensation may be as much as several liters per hour at high relative humidity. This is sometimes mistakenly regarded as a water leak.

4. Accessories

4.1 Accessories Installation

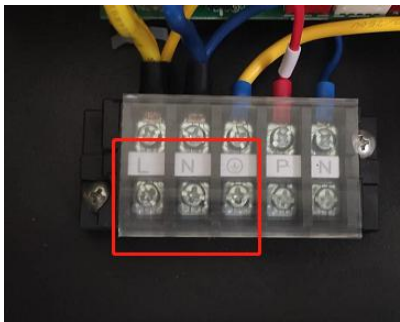
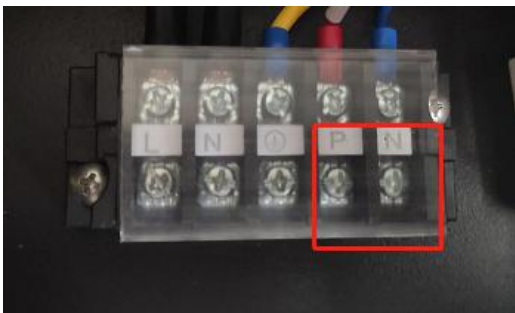
	<p>Cable wiring</p> <ol style="list-style-type: none"> 1. Open the lid of the electrical. 2. Secure the wire to the terminal block(LN part).
	<p>Water pump wiring</p> <ol style="list-style-type: none"> 1. Open the lid of the electrical. 2. Secure the wire to the terminal block (PN part)

5. Electrical Wiring

5.1 DC INVERTER SWIMMING POOL HEAT PUMP WIRING DIADRA

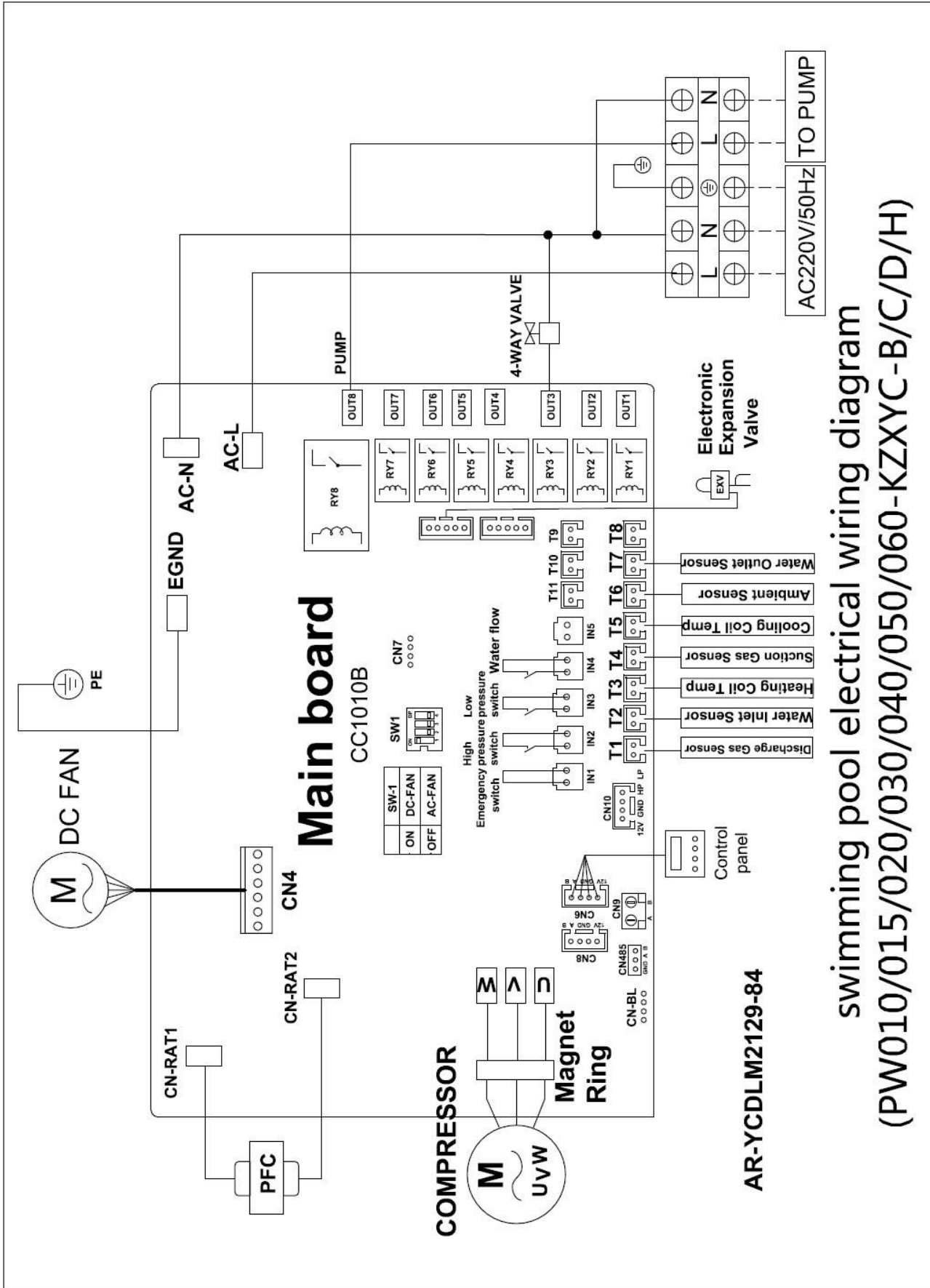

swimming pool electrical wiring diagram

(PW010/015/020/030/040/050/060-KZXYC-B/C/D/H)

NOTE:

- (1)The above electrical wiring diagrams are only for your reference, please subject the heat pump to the posted wiring diagram.
- (2)The swimming pool heat pump must be earthed well, although the unit heat exchanger is electrically isolated from the rest of the unit .Earthing the unit is still required to protect you against short circuits inside the unit .Bonding is also required.

Disconnect: A disconnect (circuit breaker, fused or un-fused switch) should be located within sight of and easily accessible from the unit .This is common practice on commercial and residential heat pumps. It prevents remotely-energizing unattended equipment and permits turning off power to the unit while the unit is being serviced.

6. Display Controller Operation

LED Display Controller

6.1 Overview

- ◎ The controller is specially designed for the swimming pool heat pump series, with features as below:
 - Heating and cooling mode;
 - Could show and change the running and setting parameters of the system,easy for user to install and test.
 - With automatic protection and fault warning function ;
 - With strong system protection function, like compressor delay protection, high pressure, low pressure, sensor protection,water flow detect etc;
 - The communication distance between the heat pump unit and remote controller shouldn't be less than 100 meters. Communication port is 485 communication.
 - Strong anti-interference, stable performance.

6.2 Basic Model of System Control Chart

- ◎ System Chart

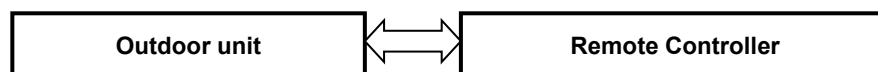











- ◎ Control Principle
 - The Outdoor unit is run according to the remote controller's order
 - The remote controller could change the running parameters and send the running parameters to the outdoor unit
 - The outdoor unit could detect the running condition and send the info or fault to the remote controller

6.3 Remote Controller (LCD Wire controller (with WIFI))





◎ Basic Icons

1. Heating mode, display symbol “”
2. Cooling mode, display symbol “”
3. When water pump is running, display symbol “”
4. “Powerful” operation mode, display symbol “**POWERFUL**”
5. “Silent” operation mode, display symbol “**SILENT**”
6. “Smart” operation mode, display symbol “**SMARTT**”
7. When compressor is running, display symbol “”
8. When defrosting, the “” display indicates defrosting operation.
9. When the fan is running, it will display “”.
10. When the WiFi connection is successful, “” will be on for a long time, it will flashing when there is no connection or in the connection.
11. When the crankshaft electric heating is on, it will display “”
12. Display “” when the screen is locked
13. “” flashes when appear the error code.

6.4 Key Operating Instruction

6.4.1、“”: ON /OFF button.

Short press“” to exit and return to the main interface.

In the main interface, long press and hold the “” key for 3 seconds to turn on / off.

6.4.2、“”: Mode button.

In the power on state, long press“” for 3 seconds to switch the working mode: heating mode and cooling mode.





6.4.3、“”: Add button.

When its turn on ,in the main interface, press “” to adjust the setting temperature of current mode;

6.4.4、“”: Reduce button.

When its turn on ,in the main interface, press “” to adjust the setting temperature of current mode











6.4..5、Parameters Query.

In the main interface, Long press and hold the “” button for 3 seconds to enter the heat pump status parameter query, Type “”、“” buttons for reading different parameters, and press the “”button to exit the parameter query.

Heat pump status Parameter table





Inquiry Code	Description	Display Range
A01	Inlet water temp	-30~99℃
A02	Outlet water temp	-30~99℃
A03	Ambient temp	-30~99℃
A04	Discharge temp	0~125℃
A05	Suction temp	-30~99℃
A06	Outer coil temp	-30~99℃
A07	Inner coil temp	-30~99℃
A08	Main EV opening	0-480
A09	Assistant EV opening	0-480
A10	Compressor current	
A11	Radiator temp	
A12	DC bus voltage	
A13	Compressor actual rotate speed	
A14	DC fan motor actual rotate speed	







6.4.7 、 Clock setting:

Press the  button to enter the clock setting state. First, the hour bit flashes, indicating that the hour value of the current time can be adjusted through the 、 buttons. Every time you press the  button add for one hour, every time you press the  button reduce for one hour. If you hold down the  button or  button for a long time, the hours will be incremented or decremented automatically. After setting the hour value, press  again. At this time, the minute flashes, indicating that the minute value of the current time can be adjusted through   button. After setting the minute value, press  again to finish.

6.4.8 、 Timing settings:

Long press  button for 3 seconds to enter timing setting:

Enter timing selection, when timing on 1" clock "flashes, hours can be set with 、 and then press  button to switch to clock" minute " , minutes can be set with 、 button.

Press the  button again to switch to the setting of "timing off 1": the clock "time" flashes, hours can be set with 、 and then press the  button again to switch to the clock "minute", minutes can be set with 、 button.
Other time periods are set and so on;



6.4.9、 Press to exit or confirm.

Press in the main interface to display the current number of set timing periods;

6.5、 Cancel timing setting:



When the set power-on time and power-off time are the same, cancel the timing setting of the current time period.

6.5.1、 Enforced Defrosting



press  and  at the same time for 5 seconds, then it enter into enforced defrosting mode.

When entering into defrosting ,  appears.

6.5.2、 Operation mode switching:

Long press “”and“”on the main interface for 3 seconds to switch operation mode: Powerful, Smart and Silent mode.







6.5.3、 Celsius / Fahrenheit switch:

In the off state, press “”and“”for 3 seconds in the main interface to switch between Celsius and Fahrenheit.

6.5.4、 Manual electric heating function

Press“”for 3 seconds in the main interface to turn on / off the electric heating function manually.

6.5.5、 System parameter setting:

Long Press and hold the“”+“”button for 5 seconds to enter the password input state. The time display position displays "0000". Press the “”or “”button to enter the password, and then press the“” key to switch the password bit. When entering the last password, press the “”key to confirm the password.

Enter the 4-digit password "0814", and enter the system parameter setting after the buzzer rings twice.





7 System Parameter:

Parameter Code	Parameter Name	Set Range	Factory Setting
P1	Return Difference for Target Water Temp.	1~18℃(2~36℉)	1℃(2℉)
P2	Set Temp. in Cooling Mode	8℃~35℃(46~95℉)	27℃(81℉)
P3	Set Temp. in Heating Mode	5℃~40℃(41~104℉)	40℃(104℉)
P4	Compensation Value of Inlet Water Temp.	-5℃~15℃(-9~30℉)	0℃(0℉)
P5	Defrosting Cycle	20MIN~90MIN	45MIN
P6	Defrosting Start Temp.	-9℃~-1℃(16~30℉)	-3℃(27℉)
P7	Defrosting Time	5MIN~20MIN	8MIN
P8	Temp.to Quit Defrosting	1℃~40℃(33~104℉)	20℃(68℉)
P9	Difference between Ambient Temp. and Coil Temp. to Start Defrosting	0℃~15℃(0~30℉)	5℃(10℉)
P10	Ambient Temp.to Start Defrosting	0℃~20℃(32~68℉)	17℃(63℉)
P11	Electronic Expansion Valve's	20S~90S	30S

	Working Cycle		
P12	Overheat Degree in Smart/ Powerful Mode	-5°C~10°C (-9~20°F)	Depends on Actual Model
P13	Exhaust Gas Temp. of Electronic Expansion Valve	70°C~125°C (158~257°F)	95°C (203°F)
P14	Electronic Expansion Valve's Steps during Defrosting (Set Value*10=Actual Steps)	2~45	Depends on Actual Model
P15	Electronic Expansion Valve's Min. Steps(Set Value*10=Actual Steps)	5~15	10
P16	Electronic Expansion Valve's Working Mode	0 Manual/1 Auto	1
P17	Manual Steps of Electronic Expansion Valve (Set Value*10=Actual Steps)	2~45	35
P18	Overheat Degree in Cooling Mode	-5°C~10°C (-9~20°F)	Depends on Actual Model
P19	Reserved	/	/
P20	Electronic Expansion Valve's Working Mode When Cooling	0=Water Temperature 1=Supercooling	0
P21	Water Pump's Working Mode When Target Temperature Reached	1= Non Stop/2= Stop 3=Intermittent	3
P22	Fan's Working Mode	0=Auto/ 1= Manual	0
P23	Fan's Manual Control Speed (Set Value*10=Actual Speed)	0-99 (Set Value*10=Actual Speed)	80 (Set Value*10=Actual Speed)
P24	Ambient Temp. to Start Auxiliary Electric Heater	-20°C~20°C (-4~68°F)	-20°C (-4°F)
P25	Auxiliary Heating Function in Defrosting Mode	Reserved	Reserved
P26	Low temperature protection value	-20°C~0°C (-22~32°F)	-20°C

Note: In the above table, the actual value of the electronic expansion valve and the air speed is 10 times of the parameter displayed value. For example, when the P20 defrost expansion valve opening degree shows 30, the actual value at this time is 300 steps; when P30 fan manual rotation speed shows 80, the actual value at this time is 800.

Restore factory settings

In the shutdown state, press and hold the “”+“”+“”+“” at the same time for 3 seconds to restore the factory settings by wire control. At this time, the buzzer will ring twice continuously, and all parameter values will change back to the default values.

8. Troubleshooting

8.1 system protection/ error indication

error code	error description	Solutions
Er 03	water flux failure	Check water flow /switch
Er 04	winter anti-freezing	Water pump will run automatically for first grade antifreeze
Er 05	high pressure failure	1. Discharge redundant refrigerant from heat pump gas system 2.Clean the water exchanger or water filter
Er 06	low pressure failure	1.Check if there is any gas leakage ,re-fill the refrigerant 2.Replace the filter or capillary
Er 09	communication failure between Display and PCB	1. Check if the communication connection wire between display and PCB is disconnected or has poor contact. Change the wire or mend it if yes. 2. Check if PCB or display is damaged. Change the corresponding part if yes.
Er 10	communication failure of frequency conversion module(alarm when communication between display and PCB are disconnected)	Change PCB.
Er 12	excessive exhaust temp protection	1. Replace the compressor discharge temperature sensor. 2. Reconnect or clean compressor discharge temperature sensor and wrap it with insulation tape. Replace the controller or PC Board.
Er 15	Water inlet temperature failure	Check or change the sensor
Er 16	external coil temperature failure	Check or change the sensor
Er 18	exhaust temperature failure	Check or change the sensor
Er 19	DC Fan motor failure	1. Check if DC fan motor is damaged. Change it if damaged. 2. Check if DC fan motor output port on PCB has output. Change PCB if no output.
Er 20	Abnormal protection of frequency conversion module	Solve it according to the subsidiary error codes in the following table.
Er 21	ambient temperature failure	Check or change the sensor
Er 23	too low cooling outlet water temp protection	Check whether the water flow or water system is jammed or not
Er 27	water outlet temperature failure	Check or change the sensor
Er 28	Total current overcurrent protection	Keep the voltage within the normal operating voltage range of the machine
Er 29	Return gas temperature failure	Check or change the sensor
Er 32	Too high heating outlet water temperature protection	Check whether the water flow or water system is jammed or not
Er 33	Outdoor coil too high temperature protection	Keep the ambient temperature within the normal operating ambient temperature range of the machine

Er 35	Compressor current protection	1. Check if the incoming voltage supply is too low, if so, repair. 2. Check if the compressor is overloaded and repair. 3. Check whether the thermal relay is damaged, if so, replace.
Er 42	internal coil temperature failure	Check or change the sensor

- © E20 fault will display the following error codes at the same time, the error codes will switch every 3 seconds. Among them, error codes 1-128 are display in priority. When error codes 1-128 don't appear, then error codes 257-384 can show. If two or more error codes appear at the same time, then display error codes accumulation. For example, 16 and 32 occur at the same time, display 48.

Error Code	name	description	Solution suggestion
1	IPM Over-current	IPM Module problem	Replace inverter module
2	compressor synchronous abnormal	Compressor failure	Replace compressor
4	reserved	--	--
8	compressor output phase absent	Compressor wiring disconnected or poor contact	Checking compressor input circuit
16	DC bus low voltage	Input too low voltage, PFC module failure,	Inspect the input voltage, replace module
32	DC bus high voltage	Input voltage too high, PFC Module failure	Replace inverter module
64	Radiator over temperature	Main unit fan motor failure, air duct blockage	Inspect fan motor, air duct
128	Radiator temperature error	Radiator sensor short circuit or open circuit fault	Replace inverter module
257	communication failure	Inverter module doesn't receive order from main controller	Inspection the communication wiring= between main controller and inverter module
258	AC Input phase absent	Input phase absent (Three phase module is effective)	Inspection input circuit
260	AC Input over-current	Input three phase imbalance (three phase module is effective)	Inspection input three phase phase voltage
264	AC Input low voltage	Input low voltage	Inspect input voltage
272	Compressor High pressure failure	Compressor high pressure failure (reserved)	

288	IPM too high temperature	Main unit fan motor failure, air duct blocked	Inspect fan motor and air duct
320	Compressor peak current too high	Compressor line current too high, the driver program doesn't match with compressor	Replace inverter module
384	PFC module over-temperature	PFC Module too high temperature	

8.2 Other Malfunctions and Solutions (No display on LED wire controller)

Malfunctions	Observation	Reasons	Solution
Heat pump is not running	LED wire controller shows no display	No power supply	Check whether cable and circuit breaker are connected
	LED wire controller displays the actual time	Heat pump under standby status	Startup heat pump to run.
	LED wire controller displays the actual water temperature	1. Water temperature is reaching set value, heat pump under constant temperature status 2. Heat pump just starts to run 3. Under defrosting	1. Verify water temperature setting 2. Startup heat pump after a few minutes 3. LED wire controller should display "Defrosting"
Water temperature is cooling when heat pump runs under heating mode	LED wire controller displays actual water temperature and no error code displays	1. Chose the wrong mode 2. Figures show defects 3. Controller defect	1. Adjust the mode 2. Replace the defect LED wire controller, and then check the status after changing the running mode, verifying the water inlet and outlet temperature 3. Replace or repair the heat pump
Short running	LED displays actual water temperature, no error code displays	1. Fan NOT running 2. Not enough air ventilation 3. Not enough refrigerant	1. Check the cable connections between the motor and fan, if necessary, they should be replaced 2. Check the location of the heat pump, and eliminate all obstacles to assure a good air ventilation 3. Replace or repair the heat pump

water stains	Water stains on heat pump unit	1. Concreting 2. Water leakage	1. No action 2. Check the titanium heat exchanger carefully if it shows any defects
Too much ice on evaporator	Too much ice on evaporator		1. Check the location of heat pump, and eliminate all obstacles to assure a good air ventilation 2. Replace or repair the heat pump

9. Maintenance

- (1) You should check the water supply system regularly to avoid the air entering the system and occurrence of low water flow, because it would reduce the performance and reliability of the heat pump.
- (2) Clean your pools and filtration system regularly to avoid the damage of the unit as a result of a dirty or clogged filter.
- (3) You should discharge the water from the bottom of the water pump if the heat pump will stop running for a long time (specially during the winter season).
- (4) On any other moment, you should check if the unit has enough water before the unit starts to run again.
- (5) After the unit is conditioned for the winter season, it is preferred to cover the heat pump with the special winter heat pump cover.
- (6) When the unit is running, there is always a little water discharge under the unit.

WIFI Controller Function Specification

Step 1. Download APP

Search and download “Smart Life” In major Application markets or Scan the QR Code below to download the App

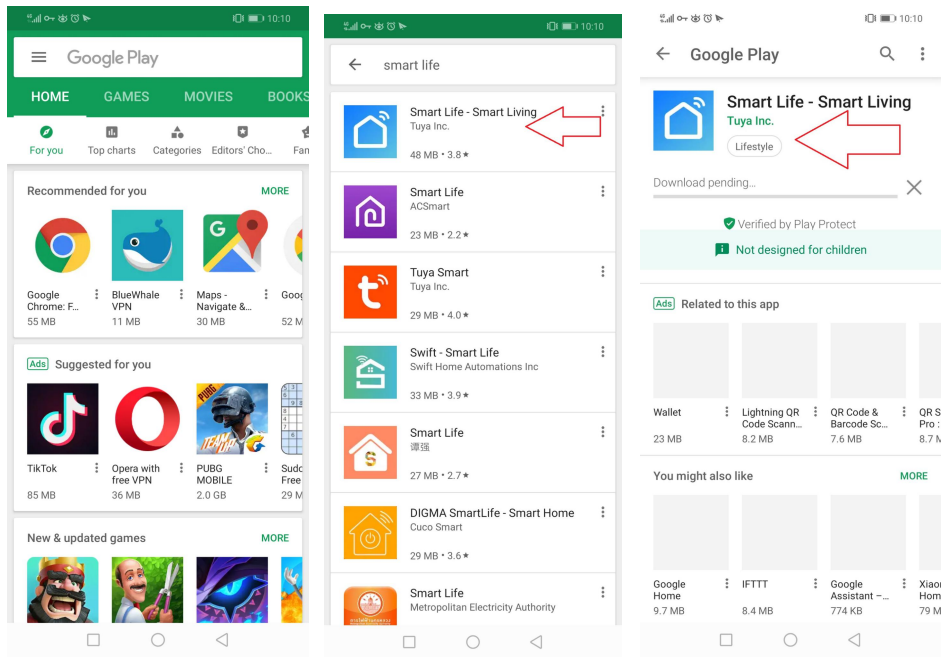

Sept 2. Registration /Login/password retrieval

Registration

If you do not have app account, you may choose to register or Log in by authorization code.

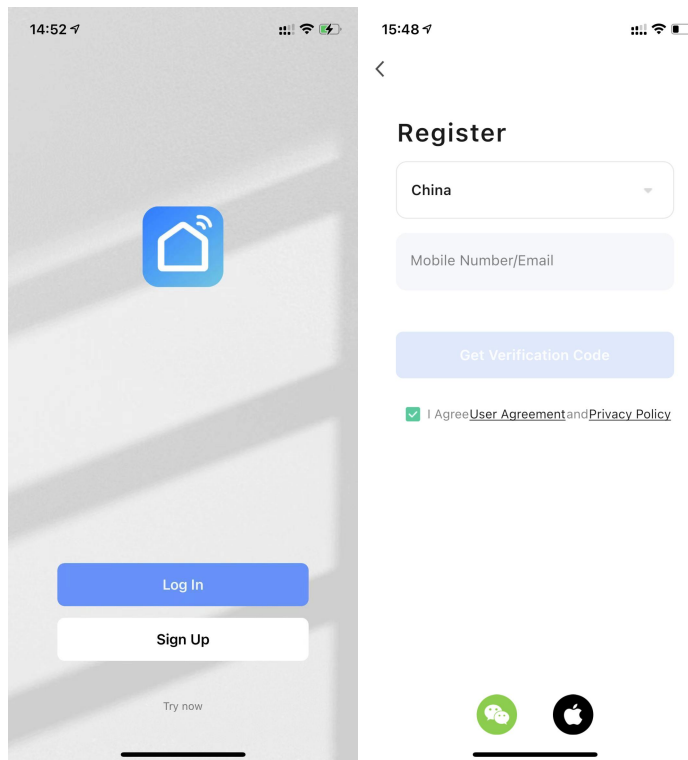

5.2 Login

If you already have an app account, please click "Log in" to enter the login page. Enter your registered mobile phone number or email, enter the password in to log in

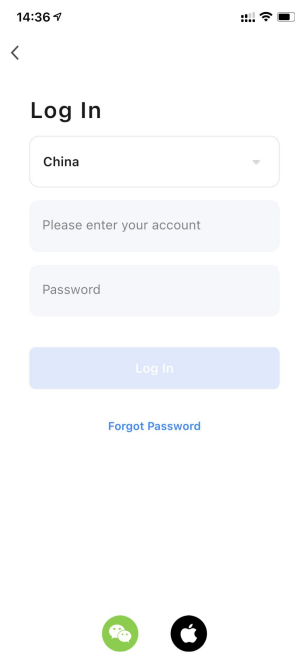

Sept 3. Add device

You have two Wi-Fi connection options. Default mode and compatibility mode.

Default mode operation

3.1 Default mode operation

press and hold the “▲” “M” at the same time for 3 seconds to enter the "default mode" to connect the Wi-Fi, the “📶” icon will flashing fast



Open“Smart life” App,Click“+” in the Upper right corner or “Add device” on the interface, Select“Water heater (WI-FI)” in “Large appliance” to enter the Wi-Fi Connection interface

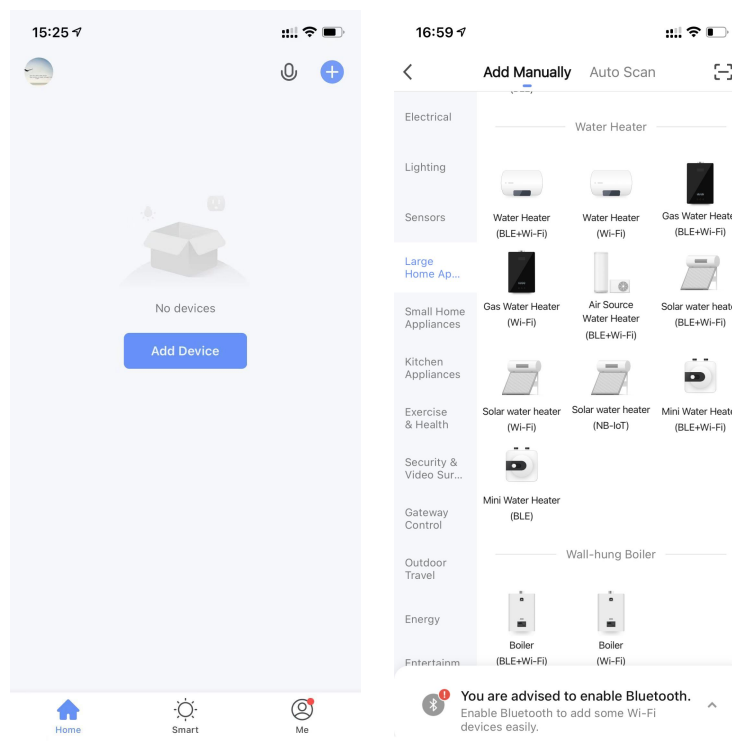

Input Wi-Fi Password (must be consistent with the Wi-Fi connected to the mobile phone), Click “next” enter the device connection status directly;

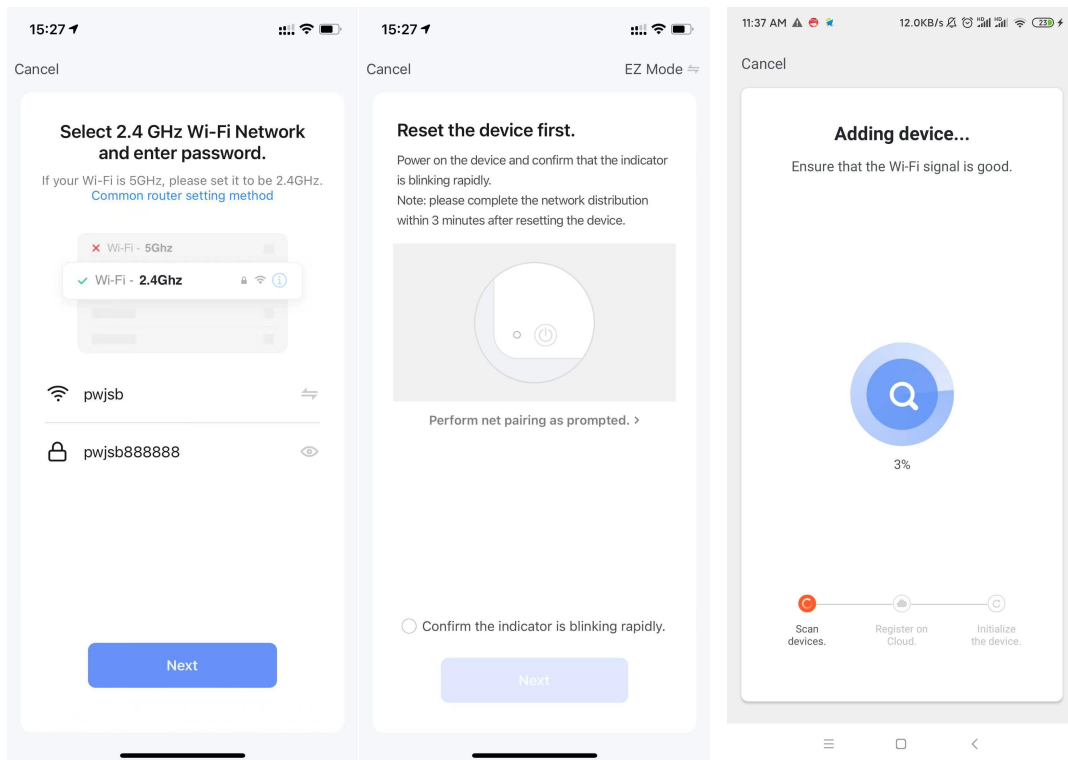



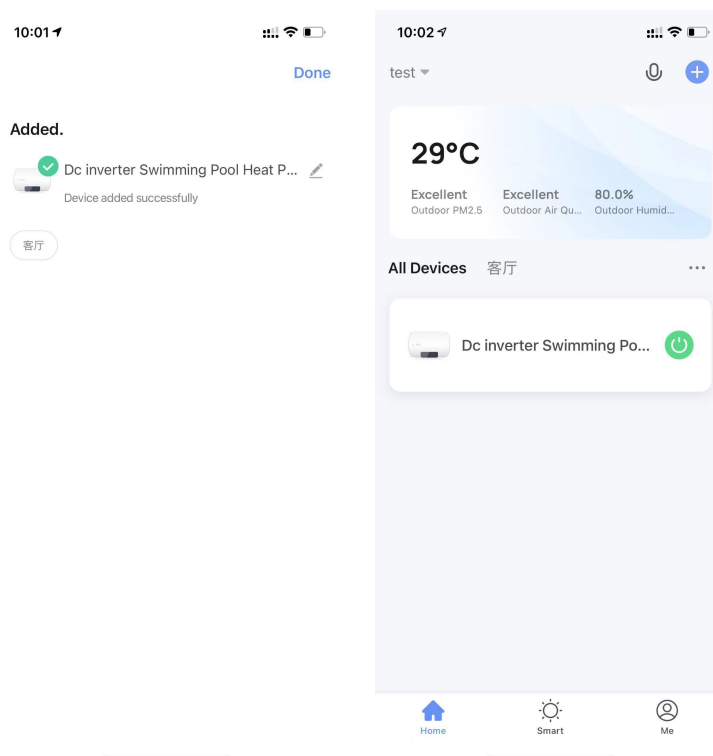

When the connection is successful, and the system prompts "added successfully", then click “Done” to directly enter the device operation main interface.



If Default mode connection not successful, Try Compatibility mode.

3.2 Compatibility mode

press and hold the “” “” at the same time for 3 seconds , the “” icon will flashing slowly

Open“Smart life” App,Click“”in the Upper right corner or “Add device” on the interface, Select“Water heater (WI-FI)” in “Large appliance” to enter the Wi-Fi Connection interface

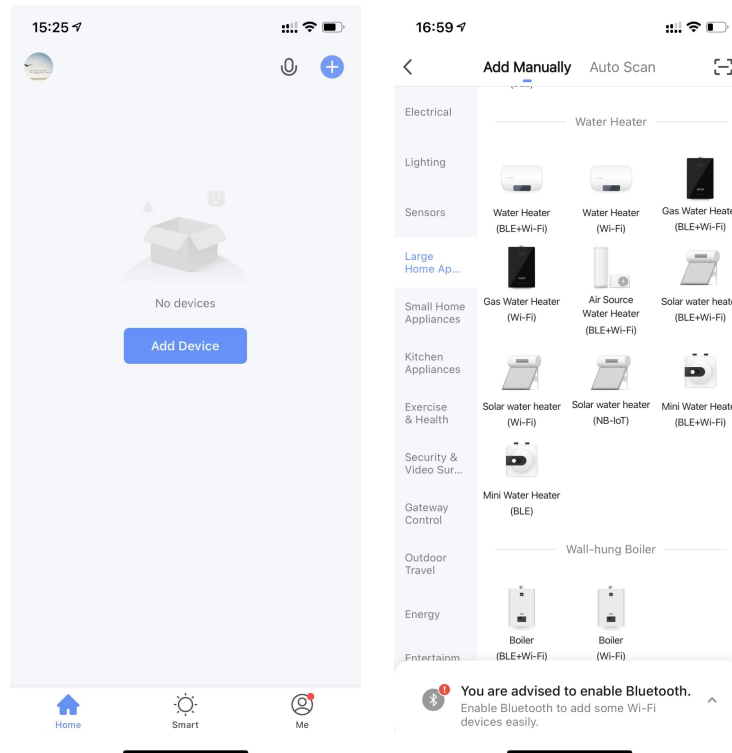

Input Wi-Fi Password (must be consistent with the Wi-Fi connected to the mobile phone),Click “next”enter the Mode selection interface;

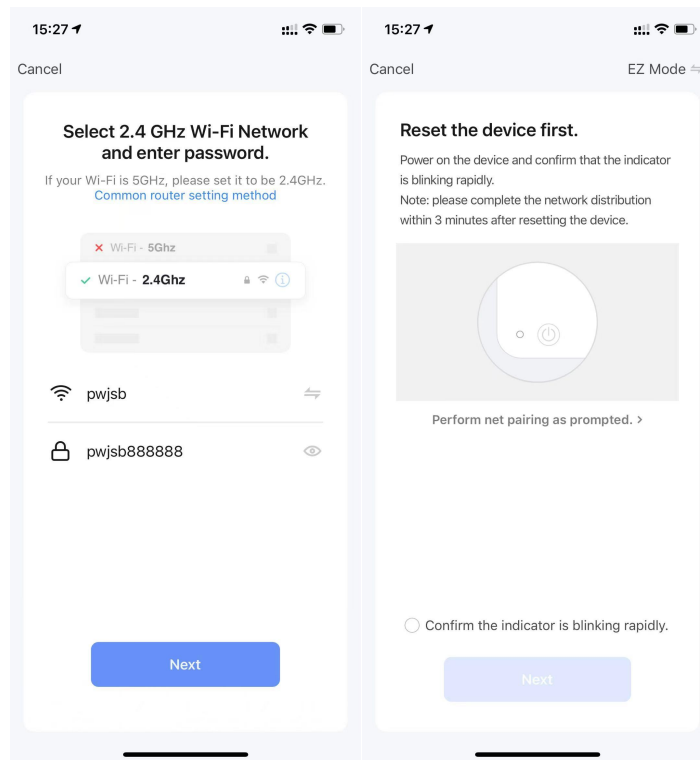

Click “EZ Mode” to switch to “AP mode”,Click “Confirm indicator slowly blink”,Click “Next ”And pop up”Connect your mobile phone to the device’s hotspot ”, Click “go to connect.

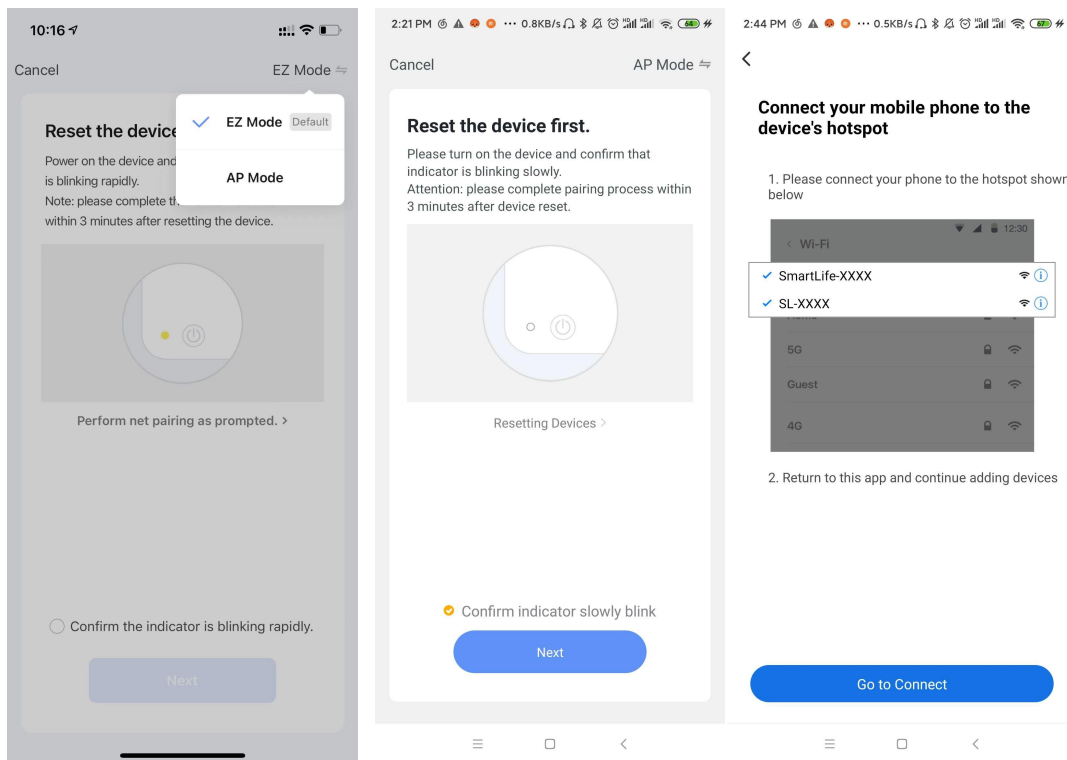

Enter the Wi-Fi Connection interface,Find and connected The desired Wi-Fi Hotspot, For examples, as pic 1”Smartlife_3C4A,” Click for Connection,APP will automatically enter the device connection state;

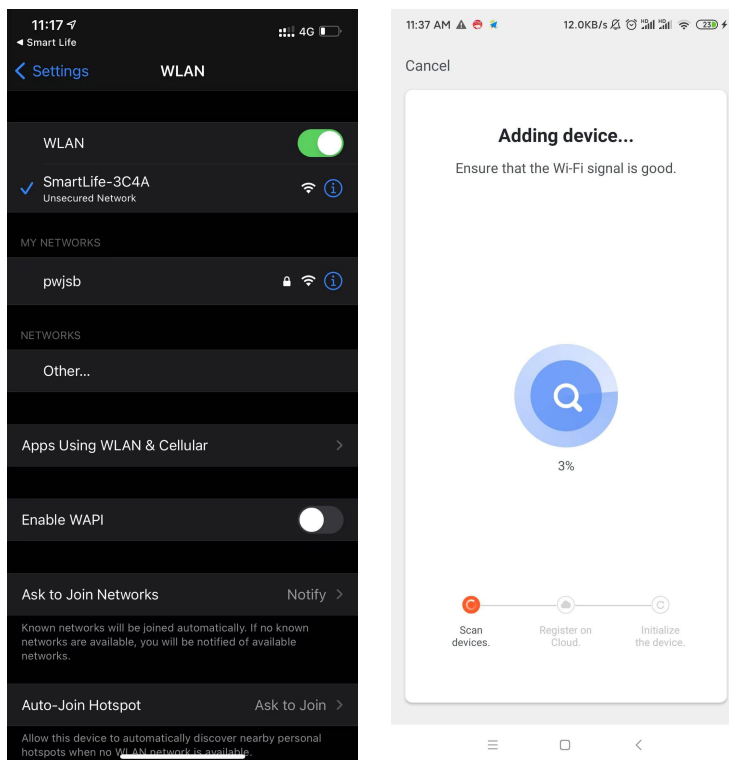

Step 4. App operation introduction

After the device is successfully bound to enter operation page



4.1 Start / Stop the heat pump

press  button to the heat pump on or off .

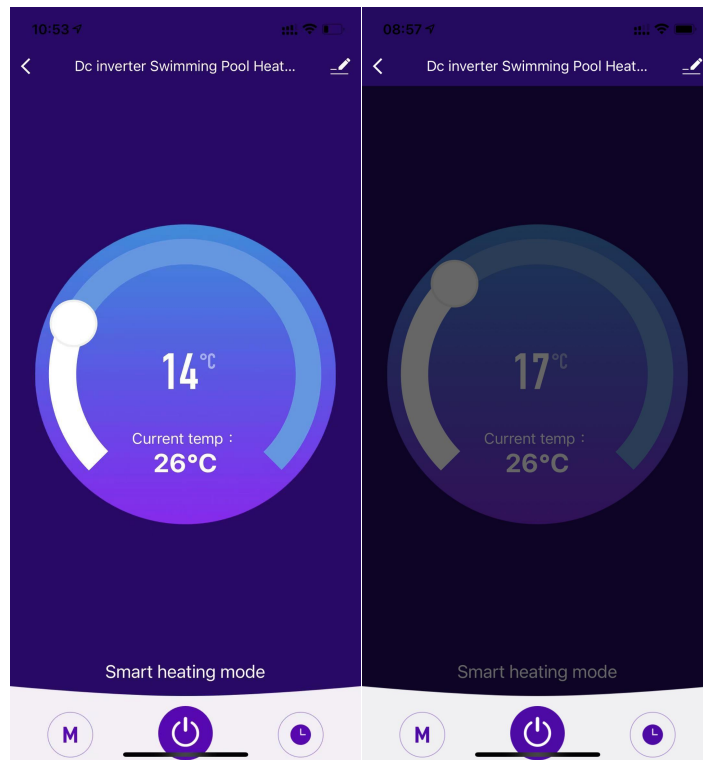

4.2 Set target water temperature

Set the target temperature by sliding the dot 

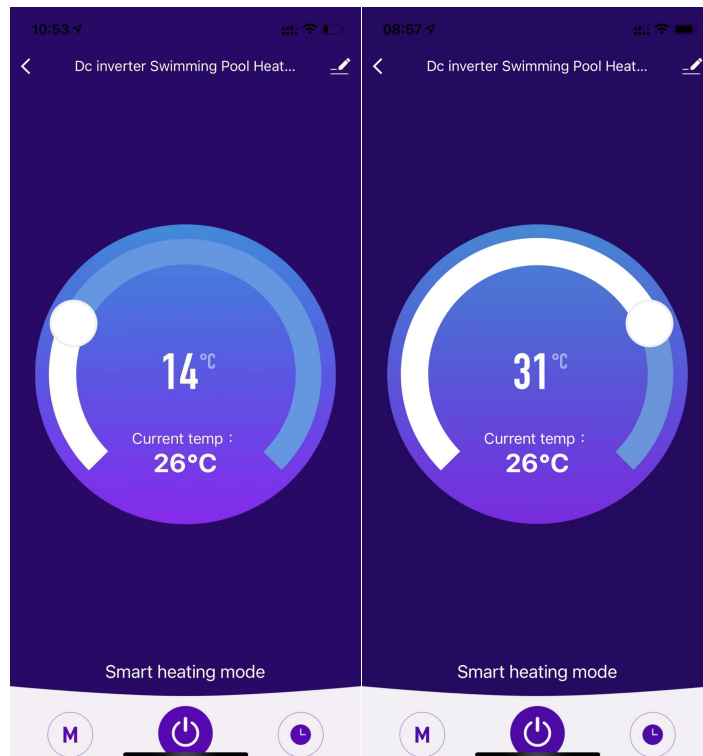

4.3 Mode setting

In the main interface, click  "The mode selection interface will pop up as shown below, just click the mode you want to select

